

DATA SHEET

UMS10GT80

10GBASE-T SFP Copper Transceiver
Low Power Version

UMS10GT80 Overview

UMS10GT80 is a newest version copper transceiver, its biggest feature are ultra low power consumption and longer transmission distance (1.6W @ 10Gbps 30m, 2.0W @ 10Gbps 80m). UMS10GT80 is a small hot-pluggable RJ45 port module, compliant with 10 Giga-bit Ethernet standards and SFP Multi-Source Agreement (MSA) standards, supporting 10G transmission rate, transfer distances up to 80 meters using Cat 6a/7 network cable, and compatible with various brands of hosts, widely used in data centers and enterprise networks. Comply with certification requirements such as RoHS 2.0, Reach, CE and FCC.

The product is based on a standard RJ45 interface, compatible with traditional networks, the Ethernet transfer rates can be increased without changing existing wiring. It is a low-cost alternative to Ethernet upgrades.

Product Features

- Low power consumption (1.6W @ 10Gbps 30m, 2.0W @ 10Gbps 80m)
- Supports 10GBase-T using 80m Cat 6a/7 cable
- Supports 1000Base-T using 100m Cat 5e cable
- Auto-sense MDI/MDIX
- Compliant with IEEE 802.3az
- Compliant with SFF-8431 and SFF-8432 MSA
- Compliant with RoHS 2.0, Reach, CE, FCC standards
- Operating temperature range:0°C to 70°C

Applications

- 10 Gigabit Ethernet

Ordering Information

Part Number	Description
UMS10GT80	1G/10GBase-T SFP+ Copper RJ-45 Connector
Note: 1. Rx with auto squelch. 2. Rx_LOS report copper interface link status. 3. A0 and A2 table 00/01 with write protection function.	

General Specifications

Parameter	Symbol	Min	Typ	Max	Unit	Remarks
Data Rate	DR		10		Gb/s	1
Bit Error Rate	BER			10^{-12}		
Operating Temperature	T _C	0		70	°C	2
Storage Temperature	T _{STO}	-40		85	°C	3
Supply Current	I _{CC}		590		mA	4
Input Voltage	V _{CC}	3.14	3.3	3.46	V	
Maximum Voltage	V _{MAX}	-0.5		4	V	
Surge Current	I _{surge}			30	mA	

Notes:

1. IEEE 802.3ae
2. Case temperature
3. Ambient temperature
4. Test at 10Gbps rate using 80m CAT 6A cable

Dimensions

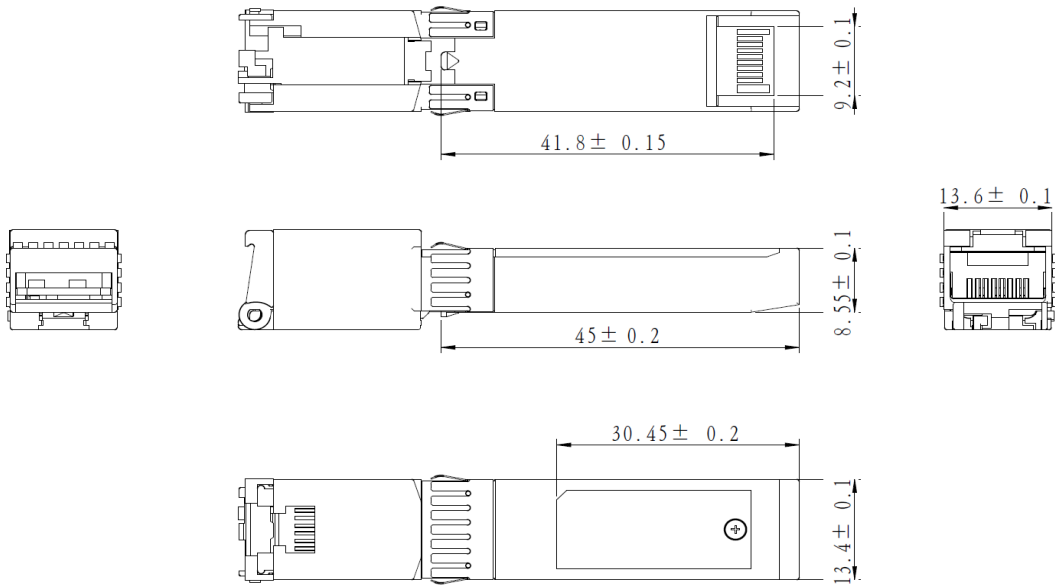

ALL DIMENSIONS ARE ± 0.2 mm UNLESS OTHERWISE SPECIFIED
UNIT: mm

Electrical Pad Layout

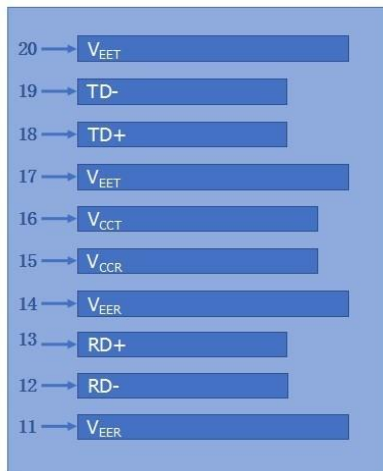

Top of Board

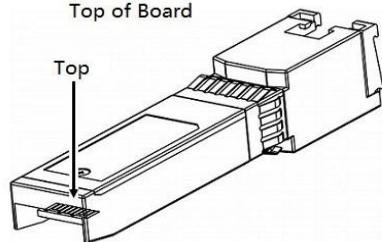

Bottom of Board

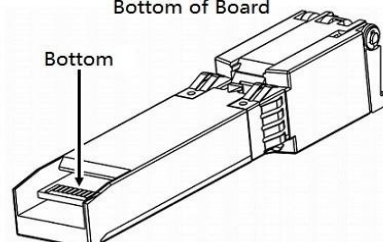

Compatible With Multiple Rates

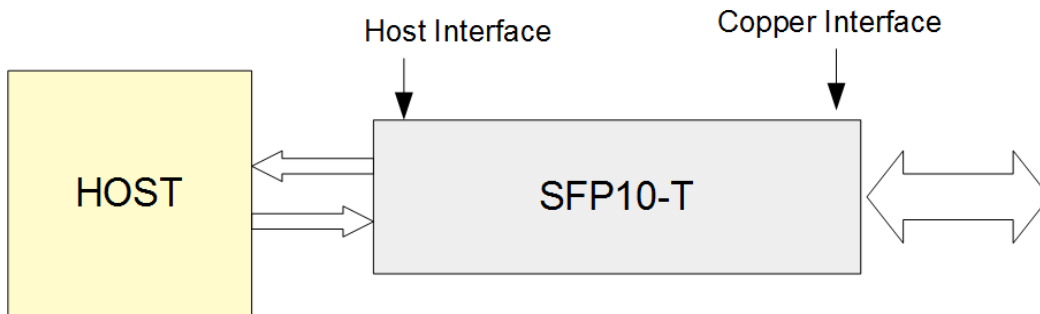

The UMS10GT80 is compatible with the 1G/10G rate. When the copper interface rate is 10G, the host interface can only be used for 10G switch port. When the copper interface rate is 1G, the host interface can only be used for 1G switch port.

Standard	Cable	Reach	Host Port	Copper Port
10Gbase-T	CAT6A	80m	10Gbase-R	10Gbps
1000base-T	CAT5E	100m	1000base-X	1Gbps

Pin Assignment

PIN #	Symbol	Description	Remarks
1	V _{EET}	Transmitter ground (common with receiver ground)	1
2	TX_FAULT	Transmitter Fault. Not supported	
3	TX_DISABLE	Transmitter Disable. PHY disabled on high or open	2
4	SDA	2-wire Serial Interface Data Line	3
5	SCL	2-wire Serial Interface Clock Line	3
6	MOD_ABS	Module Absent. Grounded within the module	3
7	RS0	No Connection Required	
8	LOS	Loss of Signal indication. Logic 0 indicates normal operation.	4
9	RS1	No Connection Required	
10	V _{EER}	Receiver ground (common with transmitter ground)	1
11	V _{EER}	Receiver ground (common with transmitter ground)	1
12	RD-	Receiver Inverted DATA out. AC coupled	5
13	RD+	Receiver Non-inverted DATA out. AC coupled	5
14	V _{EER}	Receiver ground (common with receiver ground)	1
15	V _{CCR}	Receiver power supply	
16	V _{CCT}	Transmitter power supply	
17	V _{EET}	Transmitter ground (common with receiver ground)	1
18	TD+	Transmitter Non-Inverted DATA in. AC coupled	
19	TD-	Transmitter Inverted DATA in. AC coupled	
20	V _{EET}	Transmitter ground (common with receiver ground)	1

Notes:

1. Circuit ground is connected to chassis ground
2. Disabled: T_{DIS} > 2V or open, Enabled: T_{DIS} < 0.8V
3. Should Be pulled up with 4.7k - 10k ohm on host board to a voltage between 2V and 3.6V
4. The LOS pin can indicate the connection status of the copper interface. When the copper interface is connected to the far end through the network cable, the LOS is low. Otherwise, when the network cable is disconnected, the LOS is high.
5. RD± has squelch function. When the copper interface is connected to the far end through a network cable, RX± is working normally. If the network cable is disconnected, RX± has no signal output.